

COMBISAFE®

SAFETY BY SYSTEMS

Loading System MkII

Including SkyReach Anchor

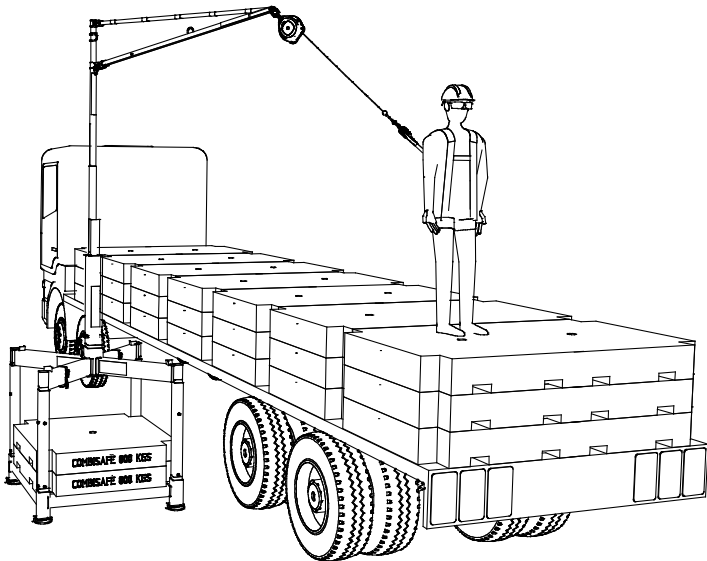

USER INSTRUCTIONS

CE 0158 - EN 795:2012-E

CONTENTS

General	3
Quick Guide.....	4
Safety Instructions	5
Remember.....	8
Technical Data	9
Main Parts	9
Loading System MkII Base.....	10
Top Column 4.7.....	11
SkyReach Adaptor 5.9.....	11
SkyReach Anchor.....	11
Optional Items	17
Assembly	20
Assembling the Loading System MkII	20
Dismantling.....	34
Transportation.....	35
Storage	37
Loading System MkII Base.....	37
SkyReach Anchor.....	38
Recommended operating method.....	39
Single Unit usage	39
Double Unit usage.....	40
Maintenance	42
Check list prior to usage.....	42
Cleaning	44
Recycling.....	44

General

The Loading System MkII has been designed to enable the loading and unloading of equipment from a flatbed truck or trailer in a safe manner.

The Loading System MkII incorporates a SkyReach Anchor unit which is connected by a Self-Retracting Cable Lifeline to the full body safety harness worn by the operative.

The SkyReach Anchor is designed to deform, absorb the energy and reduce the resulting forces, when a fall occurs.

When working at lower heights, the system can be equipped with the Top Column 4.7. In this configuration the anchor point is located 4,7 m above ground level. When working at higher positions the system can be equipped with the SkyReach Adaptor 5.9 which locates the anchor point 5,9 m above ground level. The combination of Loading System MkII and SkyReach Anchor, is tested to prove compliance to EN 795:2012 Type E, and is CE-certified by DEKRA EXAM GmbH, Dinnendahlstraße 9, 44809 Bochum, Germany, with identification no 0158.

The Loading System MkII can be used on a construction site or in a loading yard and it can be moved to alternative locations as needed. To ease transportation and storage, the Loading System MkII is designed to be flat packed and stackable. When flat packed the total height of the base is 0,6 m. The SkyReach Anchor itself can be separated and folded for ease of transport between locations.

When used for unloading a trailer up to 8 m in length, the Loading System MkII Single Unit can be used. If unloading a trailer between 8 and 14 m in length, the Loading System MkII Double Unit should be used.

Read carefully through this user instruction before use of the product. In case of questions and for clarification, please contact Combisafe for support.

Quick Guide

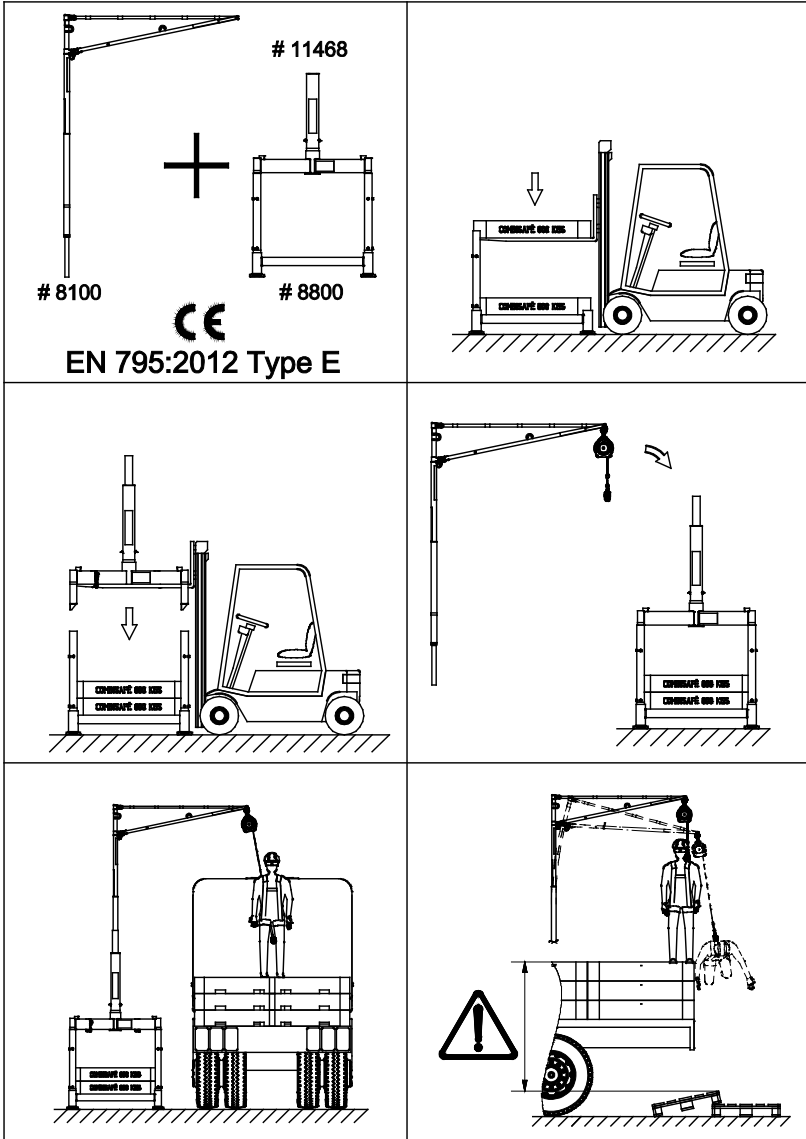

Safety Instructions

The Loading System MkII is intended for the purpose stated in this user instruction only, any other usage is not recommended. The product is used to protect workers operating at height and if used incorrectly, there is a potential risk of accidents to both the user and other people in the vicinity. Please read this manual carefully before any usage.

- Under no circumstances may the product be used as a makeshift crane or lifting/lowering device.
- Under no circumstances may any items other than those provided with the system be used either in replacement or through choice as this may affect the performance of the product.
- Care should be taken in the transportation of the product between locations. If any damage is found on any part, the item must be withdrawn from use, inspected by a trained person and replaced if required.
- Care should be taken while installing the product and if any damage occurs or is found in any part, the item should be withdrawn from use, inspected by a trained person and replaced if required.
- The site location where the Loading System MkII is being used should have a rescue plan in place, in case of a fall incident.
- The device is intended for use by one person at a time only. Under no circumstances may multiple persons be attached to the device.
- Where the base is positioned directly onto rough ground, as opposed to hard standing concrete, sole plates of suitable size and strength should be placed under the feet of the base to safely transmit and sustain a load of up to 2,5 N/mm².
- Do not lift the Loading System MkII unit or any of its components by crane, except for the SkyReach Anchor unit itself.
- When a crane is lifting the SkyReach Anchor unit, be aware of the movements made by the crane and keep workers at a safe distance.
- The SkyReach Anchor is intended to be used within a zero factor fall arrest system. Make sure that the anchorage is always overhead and the lifeline is taut between the anchorage point and the worker.
- The maximum vertical deflection of the anchor point that can occur during service is 0,7 m.
- In case this product is re-sold outside the original country of destination, it is essential that the reseller provides user instructions in the language of the country in which the system is to be used.
- When referring to any components of the system not produced by Combisafe, please refer to the specific user guide/manual for that item.

- PFPE to be used together with the Loading System MkII must be CE-certified and approved in the specific country of usage.
- It is forbidden to use the products stated in this user instruction when pregnant, suffering from cardiovascular disease, affected by alcohol or drugs or other health issues that might affect your mental or physical capacity.

Always check products and equipment before use

Check all component parts of the Loading System MkII before assembly. Never use damaged or rusty parts, as this can affect safety. Refer to the check list in the *Maintenance* chapter which must be followed prior to use.

Never combine products

It is not recommended to install, combine or interconnect products other than those supplied by Combisafe. Combisafe product liability is limited to correctly installed Combisafe products only.

Always use Personal Fall Protection Equipment

Personal Fall Protection Equipment (PFPE) must always be worn during assembly and dismantling when a risk of falling exists, see Figure 1. This also applies to work carried out from MEWPs (Mobile Elevating Working Platforms).

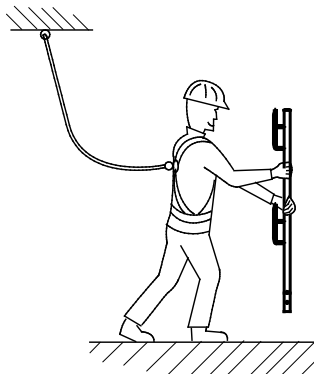

Figure 1. *Personal Fall Protection Equipment.*

Fall clearance

Note that it is essential to verify that adequate free height exists to the closest underlying object, please see Figure 2 below.

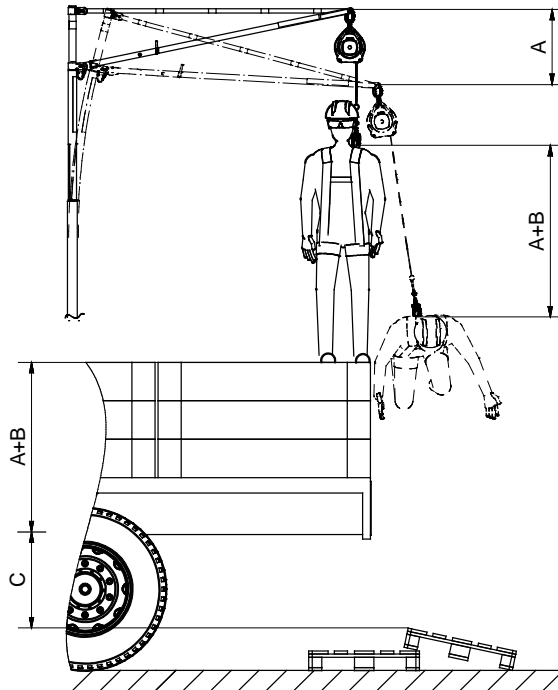

Figure 2. Explanation of fall clearance.

- A: 0,7 [m] Maximum vertical deflection of the SkyReach Anchor Point
- B: X Braking distance of the SRL. Please refer to the manufacturer's user instructions for specific values.
- C: 1 [m] Safety distance.

Total required fall clearance = A+B+C

Periodic inspection/inspection after a fall

To ensure the function and safety of the system, a safety inspection of the Loading System Base, the SkyReach Anchor and the PFPE, needs to be done by a competent person at least once every 12 months. The inspections must be documented in a component record.

If an accident has occurred, e.g. a person falls, the items must be immediately withdrawn from use and inspected by a competent person according to the manufacturer's safety check.

Please contact Combisafe for more information regarding inspections and associated documentation.

NOTE

The SkyReach Anchor is designed to deform when a fall occurs, to absorb the energy and to reduce the resulting forces. When tested, the maximum vertical deflection of the anchor point is 0,7 m.

Remember

- Plan fall prevention at an early stage, this will benefit everyone.
- Use only safety-checked products.
- Restrict access below and around installation and working area to prevent injury to others from any fall hazard.
- Use tools designed for the type of work to be carried out.
- Keep the installation area in order.
- A safe workplace is a good workplace.
- Many fall accidents occur from a low height.
- Parts might be slippery when wet, be cautious when handling.

Technical Data

Main Parts

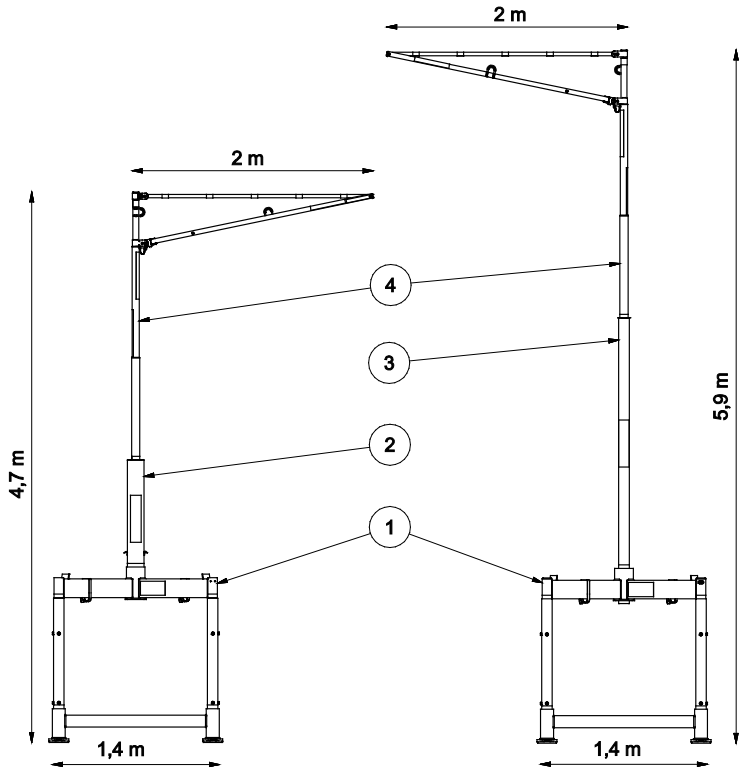

Figure 3. Main parts of the Loading System MkII with the SkyReach Anchor installed.

Item	Art no.	Designation	Weight
1	8800	Loading System MkII Base	250 kg
2	11468	Top Column 4.7	25 kg
3	8801	SkyReach Adaptor 5.9	27 kg
4	8100	SkyReach Anchor	25 kg

Loading System MkII Base

When the Loading System MkII Base is equipped with the Top Column 4.7 or the SkyReach Adaptor 5.9 and loaded with ballast it is a CE certified attachment to be used as a housing for the SkyReach Anchor.

Material: Painted steel
 Total weight:..... 250 kg
 Height:..... 1,5 m
 Width:..... 1,4 m
 Depth:..... 1,4 m

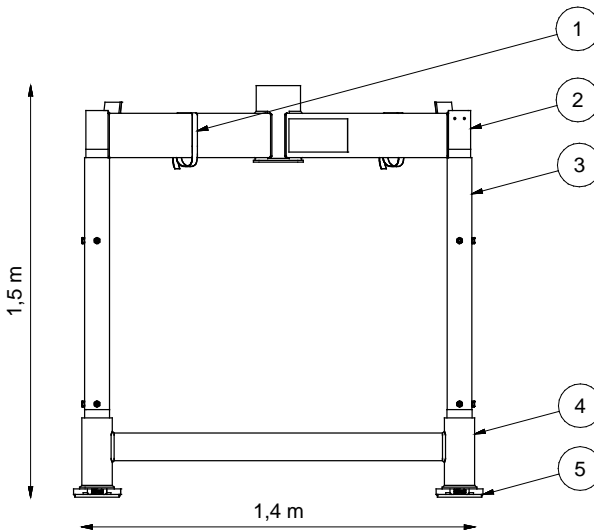

Figure 4. Loading System MkII Base.

Item	Art. no.	Designation	Weight
1	100413	Combistrap, 1 m (2 pcs)	0,1 kg/pc
2	11438	Top Frame	72 kg
3	11431	Corner Post (4 pcs)	10 kg/pc
4	11432	Bottom Frame	108 kg
5	11518	Foot (4 pcs)	2 kg/pc

Top Column 4.7

When working at lower heights the Top Column 4.7 locates the anchor point at 4,7 m above ground level. The Top Column 4.7 will fit into the Base when the Base is packed and therefore takes up no extra space when storing the item.

Material:Hot dip galvanised/painted steel
 Weight:.....25 kg
 Height: 1,2 m

SkyReach Adaptor 5.9

When a greater working height is required than the Top Column 4.7 provides, the SkyReach Adaptor 5.9 will give a total height of 5,9 m from the ground to the anchor point.

Material:Hot dip galvanised/painted steel
 Weight:.....27 kg
 Height:2,4 m

SkyReach Anchor

The SkyReach Anchor is designed to be a lightweight product and is easily foldable for moving and configured to be space-saving when transporting or storing the item, see Figure 5. To secure both positions (assembled mode and folded mode) the attached Lock Pin is used.

For lifting SkyReach Anchor by crane there are 2 lifting eyes. For lifting use 2 slings with equal length, each connected to one lifting eye (slings are not included).

Material:Hot dip galvanised/painted steel
 Weight:.....25 kg
 Height: 3,1 m
 Assembled width:.....2,0 m
 Packed width:0,2 m

NB. Suitable slings are available from Combisafe, order code 100686

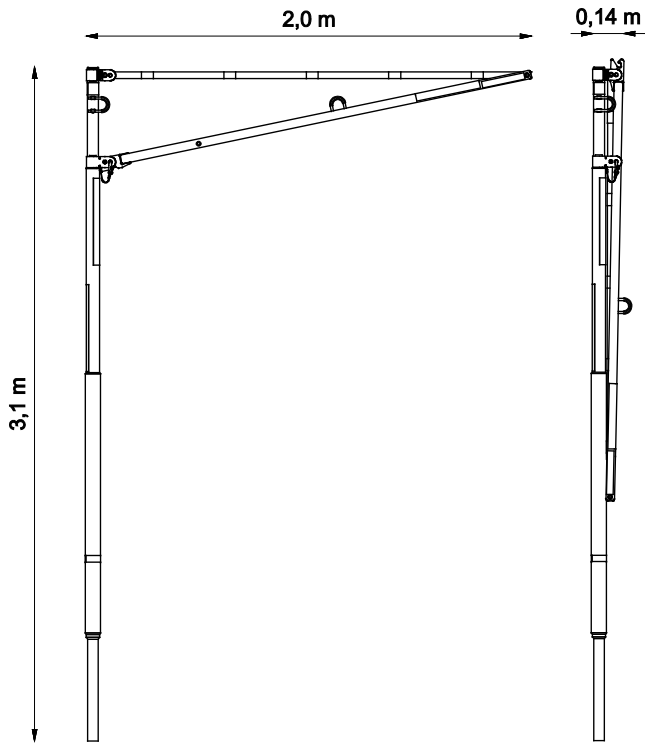

Figure 5. *The SkyReach Anchor in assembled and folded mode.*

SkyReach Anchor Labels and Markings

The Figure 6 below shows all the labels and markings of the SkyReach Anchor. The following figures (Figure 7, Figure 8 and Figure 9) are showing these important elements.

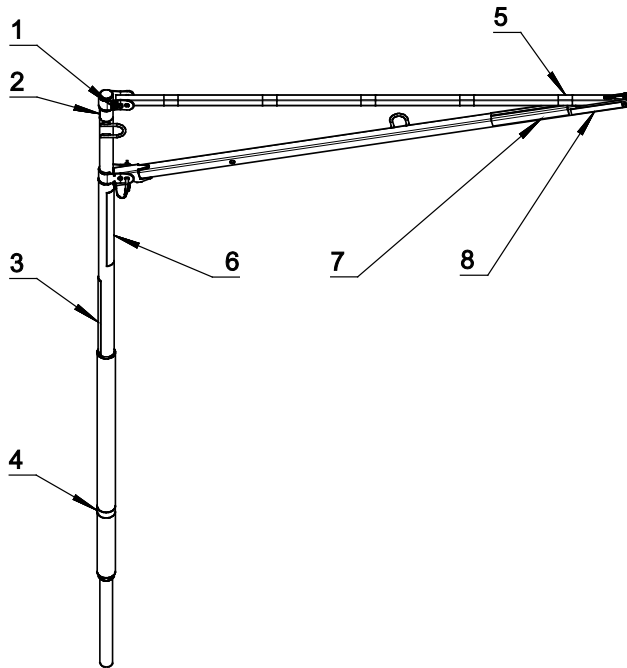

Figure 6. Labels and markings on the SkyReach Anchor.

1. ID Plate
2. Reflective Tape
3. Anti Slip Grip Tape
4. Insertion Marking Label
5. 6 x Reflective Tape
6. Combisafe Label
7. Anti Slip Grip Tape
8. Product Information Label



Figure 7. A close-up of the ID Plate including the serial number.

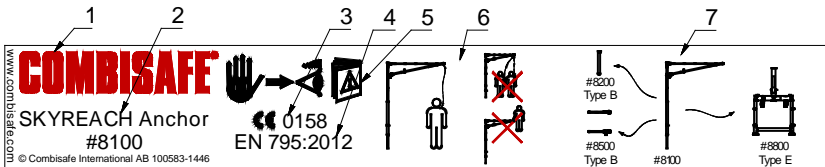

Figure 8. Detailed view of the Product Information Label

1. Manufacturer.
2. Name of the product.
3. Identification number of the notified body; DEKRA EXAM GmbH, responsible for CE production quality control.
4. Compliance with EN 795:2012.
5. Pictogram: Read user instruction before use.
6. Description of usage.
7. Product combination with different attachments.

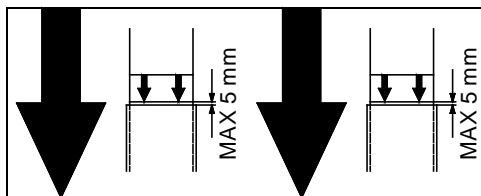

Figure 9. A close-up on the Insertion Marking Label, which shows accepted tolerances when inserting the SkyReach Anchor into its attachment.

Personal Fall Protection Equipment

To create a complete system to protect the operative when working at height, the Loading System MkII needs to be equipped with Personal Fall Protection Equipment (PFPE). Figure 10 shows an example of how to equip the SkyReach Anchor with recommended PFPE. All PFPE that is used must be certified according to valid standards and approved in the specific country of use.

The following PFPE is approved to be used together with the SkyReach Anchor and the Loading System MkII:

- SRCL Fall Arrest Block certified to EN 360
 Only the Miller Falcon 6,2 m, or the Miller Falcon 10 m when a Double Unit is used, has been tested and approved in combination with the Loading System MkII and SkyReach Anchor, and thus the only SRCL that will enable the system to be CE certified. **Use of other SRCL will invalidate the CE certification.**
- Harness Full body harnesses certified to EN 361
- Lanyard Non shock absorbing lanyards certified to EN 354
 Can be used separately or in combination with EN 355 certified lanyard, or with a max length of 0,6 m in combination with the Falcon Fall Arrest Block.
- Lanyard Shock absorbing lanyards certified to EN 355
 Can be used separately or in combination with an EN 354 certified lanyard. Must **NOT** be combined with the Falcon Fall Arrest Block.

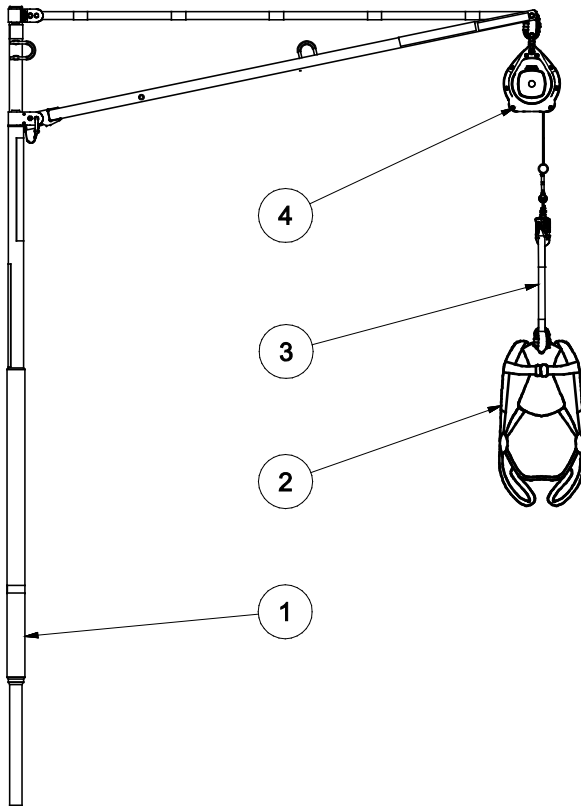

Figure 10. The figure shows the SkyReach Anchor equipped with recommended PFPE.

Item	Part no.	Designation	Weight
1	8100	SkyReach Anchor	25 kg
2	-	Full body harness certified to EN 361	-
3	CM1002889	Miller Extra Webbing, 0.3 m	0,2 kg
4	CM1011729	Miller Falcon SRCL, 6.2 m	4 kg

Optional Items

The following items are not delivered as standard together with the Loading System MkII but can be ordered separately if required, please see Figure 11 for visual clarification of the items.

Precast Kentledge (Art. 11655)

This precast concrete block is one out of three possible ballast options, and can be ordered from Combisafe. Please see the following chapter *Ballast* for more information.

Material:Concrete
 Weight:800 kg
 Height:0,2 m
 Width:1,4 m
 Depth:1,4 m

Formwork Support (Art. 11446)

To use the second ballast option, the Loading System MkII Base needs to be equipped with 8 pcs of the Formwork Support. These channel section steel bars with a wooden inlay will give the support needed to the side boards when the base is filled with gravel or concrete.

Material:Painted steel/wood
 Weight:11 kg
 Length:1,4 m

SkyReach Reach Hook (Art. 11530)

The Reach Hook is useful to guide the SkyReach Anchor into the Top Column 4.7/SkyReach Adaptor 5.9 when the anchor is lifted and lowered by crane. It has a telescopic shaft which is extendable from 1,2 to 2,7 m.

Material:Aluminum/Hot dip galvanised steel
 Weight:1,0 kg
 Length:1,2 – 2,7 m

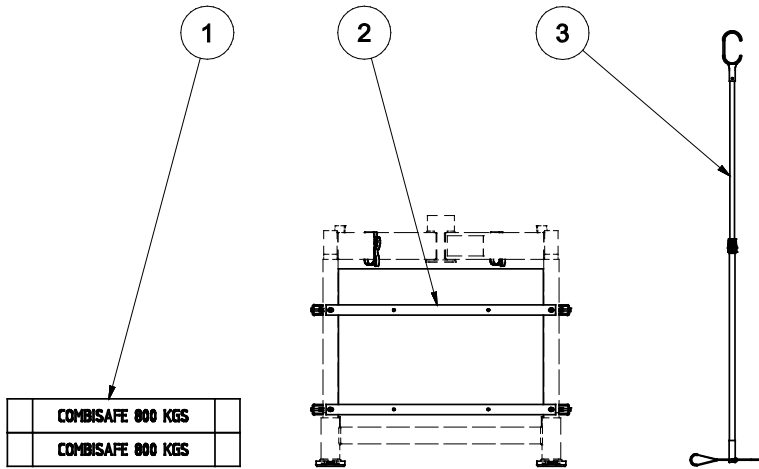

Figure 11. *Optional items.*

Item	Part no.	Designation	Weight
1	11655	Precast Kentledge (2 pcs needed)	800 kg/pc
2	11446	Formwork Support (8 pcs needed)	11 kg/pc
3	11530	SkyReach Reach Hook	1,5 kg

Ballast

The Loading System MkII Base needs to be loaded with a minimum 1500 kg of suitable ballast to keep it stable and meet the requirements in the standard. The ballast can be applied in three different ways, which are presented below. Further details on how to perform the ballast loading procedures are described in the *Assembly* chapter.

- **Precast Kentledge**

The Precast Kentledge is a 800 kg concrete block designed to fit into the Loading System MkII Base. Using two units of the Precast Kentledge is enough to achieve the weight requirement and provide margin in case of wear of the blocks. These should be ordered as an option as they are not included as a standard. It is recommended to use these blocks due to its precise weight and safe positioning.

- **Concrete box cast on site or gravel box**

For this option, the Formwork Supports should be ordered, as they are not included in Loading System MkII as standard. With the Formwork Supports mounted, a plywood box inside the Loading System MkII Base will make it possible to cast concrete into the box directly on site. It is also possible to fill the plywood box with gravel.

- **Other ballast option**

In case none of the standard solutions noted above is used, it is possible to use other ballast types. In this case it is the customer's responsibility to ensure that ballast:

- Has a weight no less than 1500kg
- Is distributed centrally on the Bottom Frame of Loading System MkII
- Has no possibility of movement.

Assembly

Assembling the Loading System MkII

The following information and illustrations are a step by step guide on how to rig a Loading System MkII together with a SkyReach Anchor unit successfully. The Loading System MkII can be used with any of the three ballast options described. Please refer to the appropriate instruction pertaining to the actual case.

Before attempting to rig a Loading System MkII unit, please make sure you have the following tools:

- Hammer, 22 mm spanner or adjustable spanner for adjusting the feet
- Spirit level.
- Crane for installation of the SkyReach unit.
- Fork lift truck, or equivalent, for lifting the component parts.

NOTE

Except for lifting the SkyReach Anchor unit alone, lifting the Loading System MkII, or its parts with a crane is not permitted. Use a fork lift truck and refer to the guides in this document.

Installation instructions for Loading System MkII

1. Make sure that the ground, where the Loading System MkII is placed, is relatively flat. The Loading System MkII Base has adjustable feet which are designed to adjust within a 5 degree inclination. Use a fork lift truck to handle the Bottom Frame, place the forks underneath the horizontal tubes and spread the forks apart prior to lifting, see Figure 12. Place the Bottom Frame on the ground. Use a spirit level to make sure that the Bottom Frame is level. If not, rotate the feet by hand or use a 22 mm spanner or a hammer to strike on the Adjusting Bar to adjust the feet until the Bottom Frame is level, see Figure 13.

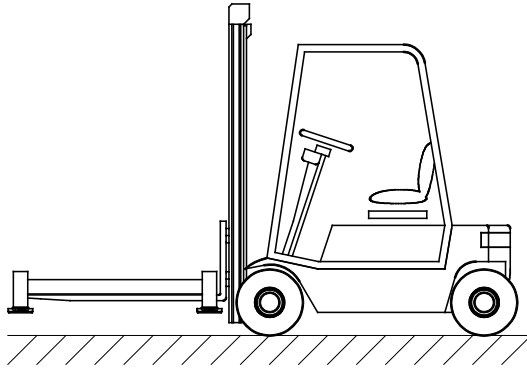

Figure 12. *Lifting the Bottom Frame with a fork lift truck.*

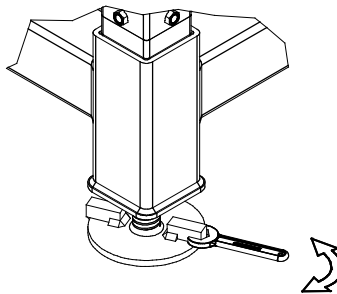

Figure 13. *Adjustment of the Foot height with a 22 mm spanner.*

2. Place the four Corner Posts into the Bottom Frame, with the welding nuts facing outwards. (When using the Precast Kentledge as ballast, it is recommended to insert only the two rear Corner Posts before loading the ballast.)

Make sure that the Corner Posts are inserted the correct length into the sleeves, observe the Insertion Marking Label position, see Figure 14.

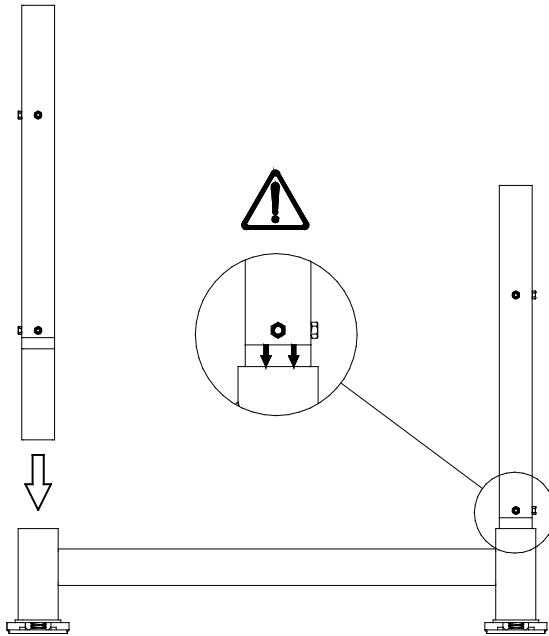

Figure 14. Insertion of the Corner Posts.

NOTE

The lower edge of the Insertion Marking Label on the Corner Posts must be aligned with the upper edge of the Bottom Frame Posts for a safe and proper installation. See Figure 15 below for a closer illustration of the label.

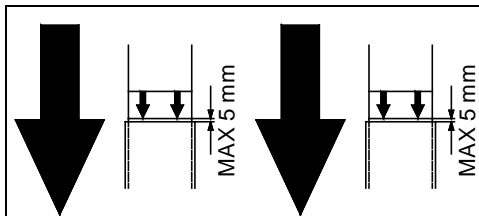

Figure 15. Close-Up of Insertion Marking Label.

If using Precast Kentledge as the ballast option, please proceed to step 3. If using cast concrete as the ballast option, please proceed to step 4 and if using gravel as the ballast option, please proceed to step 5.

3. **Precast Kentledge ballast option**

Check that the two rear Corner Posts are inserted correctly, and the two front Corner Posts are left to one side. Use a forklift truck to place two 800 kg COMBISAFE Precast Kentledge onto the Bottom Frame, see Figure 16. When the concrete block is in place, place the two remaining Corner Posts into the Bottom Frame. Next step is to mount the top unit, please proceed to step 6.

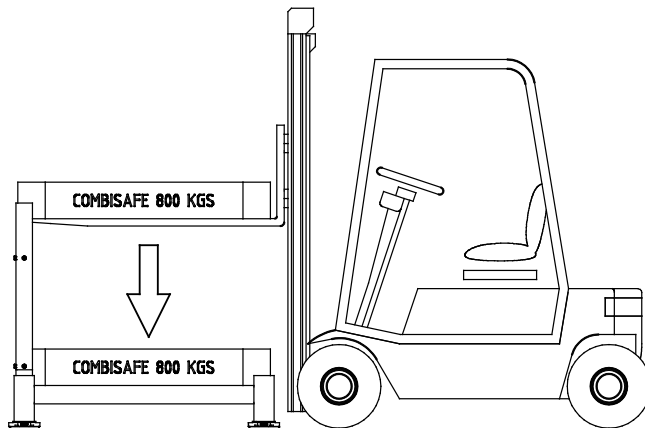

Figure 16. Placement of last ballast.

4. **Cast-In-Concrete ballast option**

4.1 Check that all four Corner Posts are inserted correctly into the Bottom Frame. Cut a piece of 18 mm Formwork Plywood, complying with EN 636-3, in the format as shown in Figure 17 and place in the centre of the Bottom Frame. Bolt the eight Formwork Supports to the welding nuts located on the Corner Posts. Use the bolts attached to the Formwork Supports, see Figure 18. At this step it is not necessary to tighten the bolts.

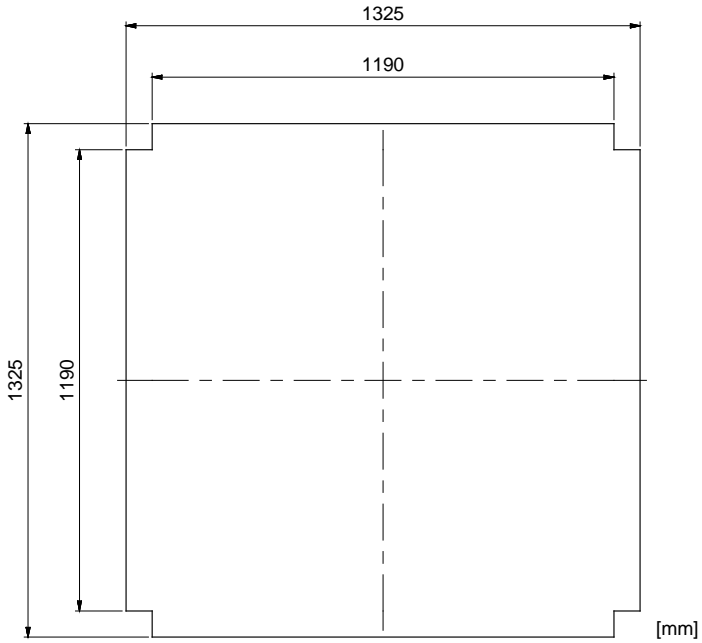

Figure 17. Dimensions for the bottom board.

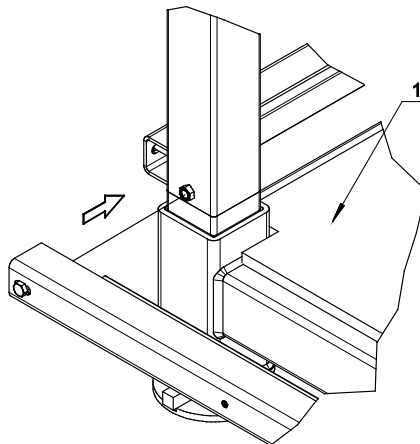

Figure 18. Example of placement of Formwork Support.

- 1. Bottom Board

- 4.2 Cut twelve 70x45 wooden ribs to 920 mm in length and four pieces of 18 mm Formwork Plywood, complying with EN 636-3, to the format 1285x920 mm and cut out a notch in one corner as shown in Figure 19. Make four similar side board units according to these instructions, and then fix the ribs to the boards with wooden screws as in Figure 19.

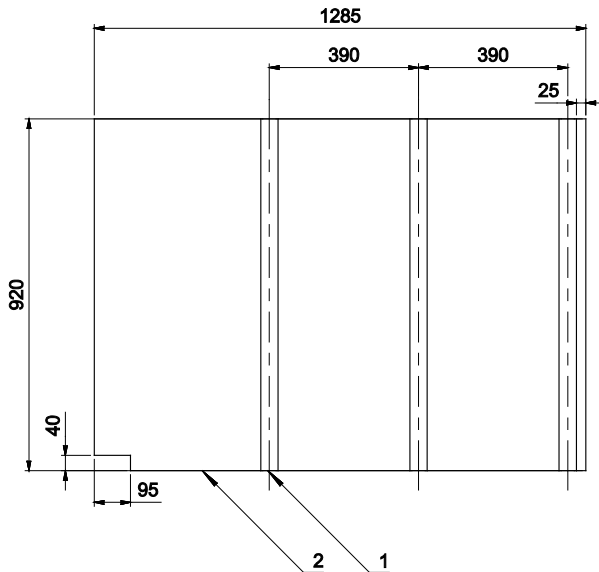

Figure 19. Dimensions for the concrete side board.

1. 3 x Wooden Rib (45x70x920)
 2. Concrete Side Board
- 4.3 Place the four Concrete Side Board assembly units equally one after another onto the Bottom Board located in the Base, with the notch facing down and the Wooden Ribs leaning towards the Formwork Supports, see Figure 20. Make sure to place all the units overlapping so that all the sideboard units get the same support when leaning against the Formwork Supports.

NB. Suitable base and side boards are available from Combisafe, order code 11595

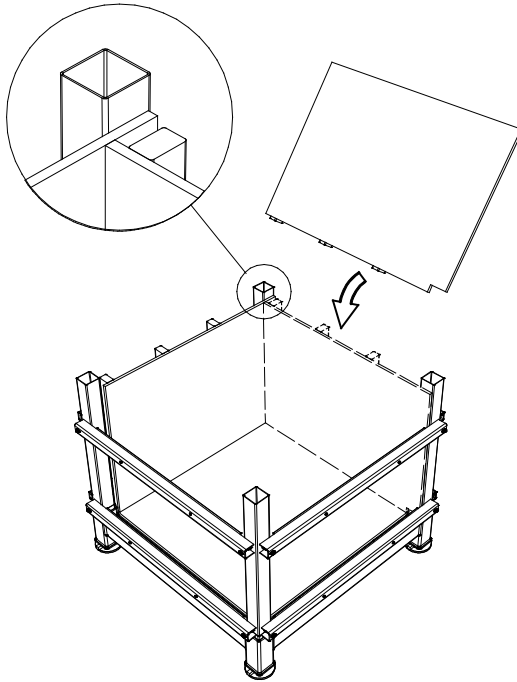

Figure 20. Placement of the side board units.

4.4 When all the sides are in place and the plywood boards create a tight box, fix the boards with wooden screws if needed. Please proceed to step 6 for mounting of the top frame.

5. Gravel filled ballast option

5.1 Check that all four Corner Posts are inserted correctly into the Bottom Frame. Cut a piece of 18 mm Formwork Plywood, complying with EN 636-3, to the format as shown in Figure 21 and place in the centre of the Bottom Frame. Bolt the eight Formwork Supports to the welding nuts. Use the bolts attached to the Formwork Support, see Figure 22. At this step it is not necessary to tighten the bolts.

NB. Suitable base and side boards are available from Combisafe, order code 11594

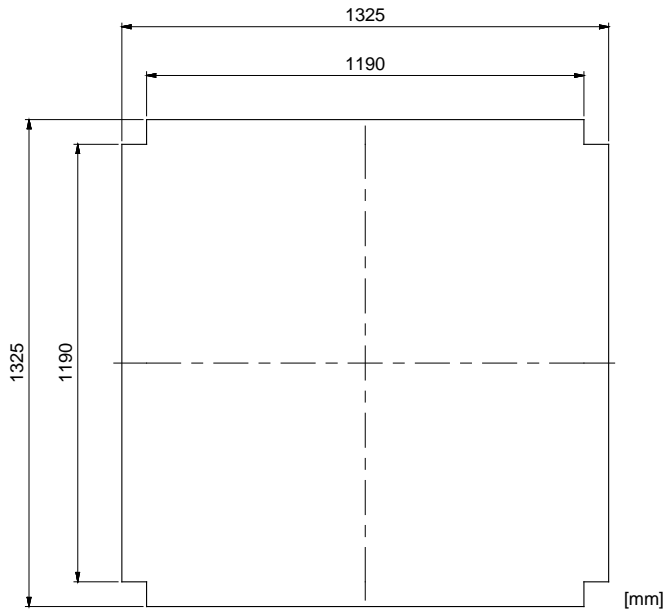

Figure 21. Dimension of the Bottom Plywood Board.

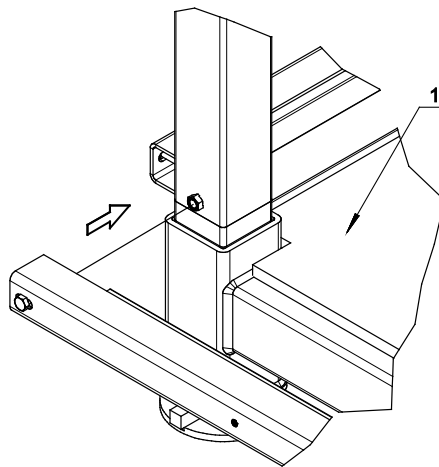

Figure 22. Example of placement of Formwork Support.

1. Bottom Board

5.2 Cut four pieces of 18 mm formwork plywood, complying with EN 636-3, to the format as shown in Figure 23. Place the boards one after another in the Base, with the notches facing down, leaning against the Formwork Supports, see Figure 24. The boards shall be placed onto the Bottom Frame itself and not onto the Bottom Board. Fix the boards to the Formwork Supports with wooden screws. When all the boards are in place and they create a box, go to step 6 for mounting of the Top Frame.

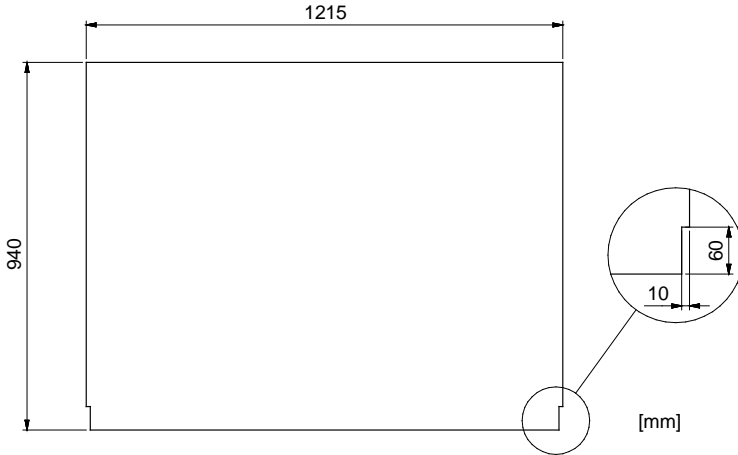

Figure 23. Dimension of the gravel side board. Note that the board has got notches in both bottom corners.

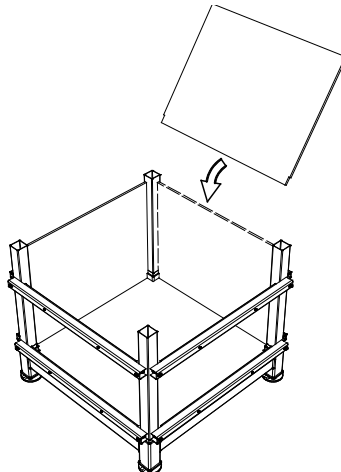

Figure 24. Placement of the side board units.

- When using the SkyReach in the Loading System MkII unit, the Top Column 4.7 can be used to provide an anchor point located 4,7 m above ground level. If greater working height is preferred, then chose the SkyReach Adaptor 5.9 instead. With this solution, the anchor point will be located 5,9 m above ground level. The following instructions can be applied to both of the solutions but the illustrations are showing the Top Column 4.7 only.

With the Top Frame still standing on the ground, insert the Top Column 4.7/SkyReach Adaptor 5.9 unit into the Top Frame, observing that the Insertion Marking Label is in position, see Figure 25.

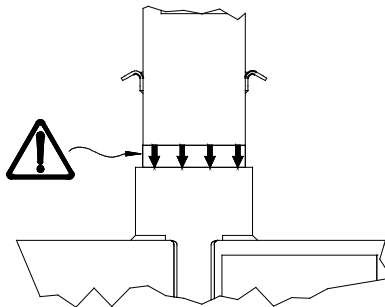

Figure 25. Insertion Marking Label on Top Column 4.7.

NOTE

Make sure that the Top Column 4.7/SkyReach Adaptor 5.9 is inserted the correct length into the Sleeve. Insertion Marking Label on Top Column 4.7/SkyReach Adaptor 5.9 must be aligned with upper edge of Top Frame Sleeve for a safe and proper installation.

- Using a forklift truck, place the forks underneath the horizontal tubes of the Top Frame, spread the forks as wide as possible and then, if needed, secure the Top Frame assembly with the two supplied Combistraps before lifting. Straps shall be attached diagonally to each fork to ensure a safe lift, see Figure 26 below. Remember that the straps should be tightened firmly.

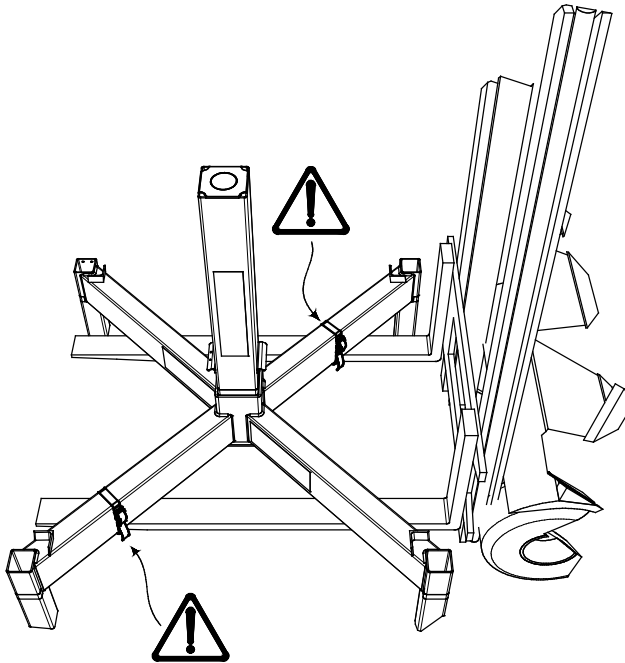

Figure 26. Use the included Combistraps to secure the Top Frame to the forks prior to lifting.

8. Lift the assembled top unit high enough above the Corner Posts, and slowly lower the assembly when the four Top Frame Legs can be slotted into the Corner Posts. If Formwork Supports are bolted to the Corner Posts, make sure they are not tightened, thus it can prevent the Top Frame from being inserted in an easy way. Lower the assembly slowly and make sure it runs smoothly down into the Corner Posts.

Make sure the assembly is inserted the correct length by checking that the lower edge of Insertion Marking Labels are aligned with upper edge of Corner Posts, see Figure 27.

With the Top Frame in place, the Formwork Supports can be tightened firmly, if they are being used.

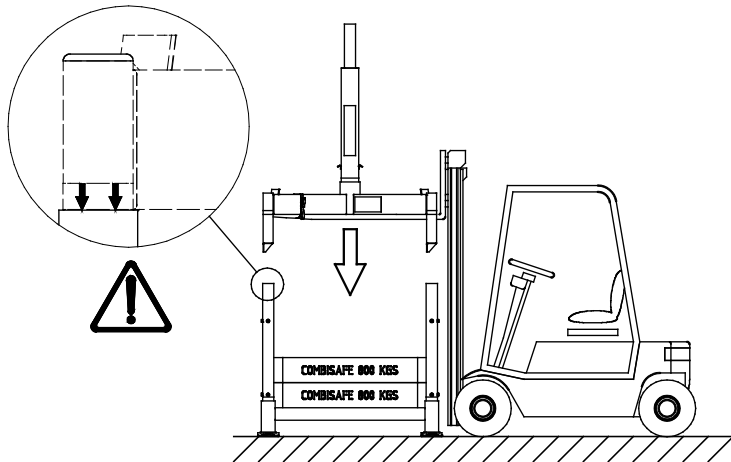

Figure 27. Insertion of Top Frame to Corner Posts. Note the position of Insertion Marking Label when Top Frame is slotted into the Corner Posts in the illustration to the left.

Now the Loading System MkII Base is completed as an assembled unit and equipped with either the Top Column 4.7 or the SkyReach Adaptor 5.9. If concrete or gravel is preferred as ballast option, or if other ballast option is chosen please proceed to step 9. If the Precast Kentledge is used as ballast, please proceed to step 10.

9. If concrete is the chosen ballast option, fill the box in the base with concrete. Concrete must be distributed evenly on the bottom board.

If gravel is the preferred ballast option, fill the box up with gravel, compact well and make sure there is no gap in the gravel box to avoid losing gravel out of the box.

If a non-standard ballast option is chosen, make sure that ballast is distributed centrally and secured against free movement. The ballast must be placed inside the unit in between Bottom Frame and Top Frame at all times when in use.

NOTE

In all cases ballast must be centred in the unit and its weight must be minimum 1500kg. Otherwise the safe function of Loading System MkII is not warranted.

10. **Installation instructions for the SkyReach Anchor**

10.1 Mount the SkyReach Anchor from the folded position in four easy steps, please see Figure 28:

1. Remove the Lock Pin and release the SkyReach Anchor Brace and Boom.
2. Arrange the position of the Boom.
3. Move the SkyReach Anchor Brace and make sure that the brace hook bracket (detail A) fits into the lower lugs (detail B).
4. Secure the position from step 3 with the attached Lock Pin as shown in view C.

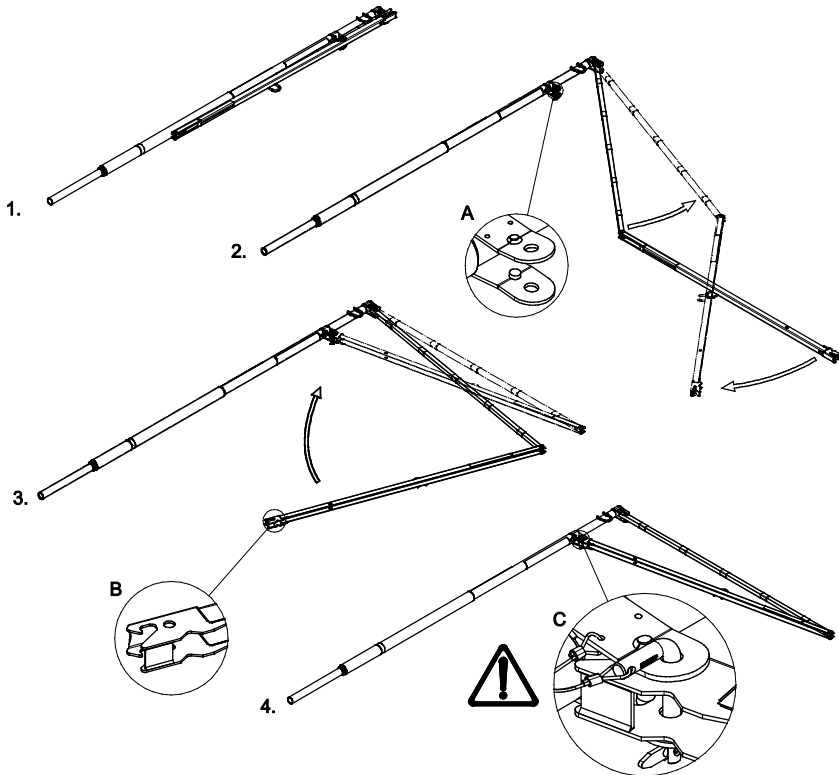

Figure 28. Assembly process of the SkyReach Anchor

NOTE

Make sure that the Lock Pin is properly installed, latch is dropped and that it is secured with the wire. Under no circumstances shall a substitute Lock Pin other than ones provided by Combisafe be used.

- 10.2 Connect the Fall Arrest Block. Make sure that the component is correctly attached and secured to the SkyReach Anchor point. Figure 29 shows how the 6,2 m Falcon Fall Arrest Block is attached to the anchor point.

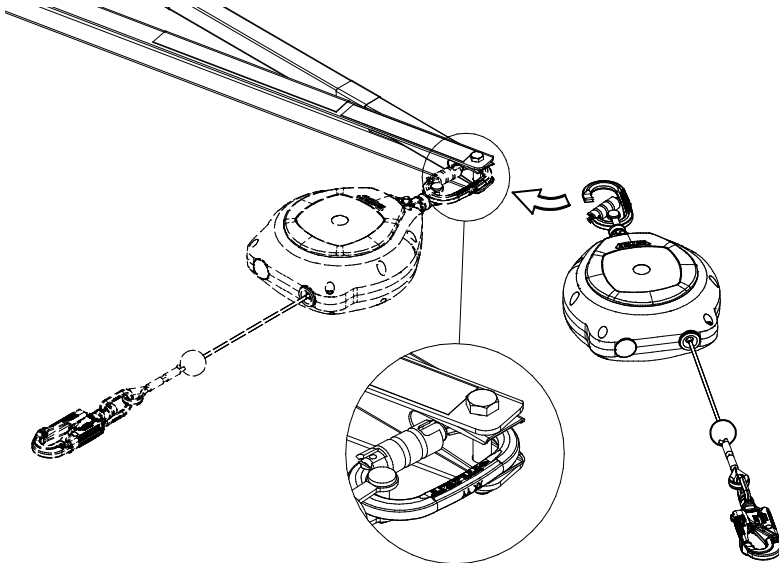

Figure 29. Attaching the 6,2m Fall Arrest Block.

NOTE

It is strongly recommended that a retrieving rope is tied to the Fall Arrest Block karabiner to enable the operative to pull the cable out and allow simple connection to the operative's 0.3 m harness extender. It is not recommended to leave the cable of the block pulled out in this matter, due to possible damage to the unit.

- 10.3 It is recommended to attach the slings to the lifting eyes on the SkyReach. This slings will help correct positioning of SkyReach. The lifting eyes on the SkyReach Brace are not designed as anchorage points, avoid any usage other than stated in this User Instructions.
11. Use a crane to lift the assembled SkyReach Anchor and lower it into the Top Column 4.7/SkyReach Adaptor 5.9, see Figure 30. Use the Reach Hook to guide the SkyReach into place if needed. Make sure that the correct length of the SkyReach is inserted, please observe the Insertion Marking Label position, see Figure 30.

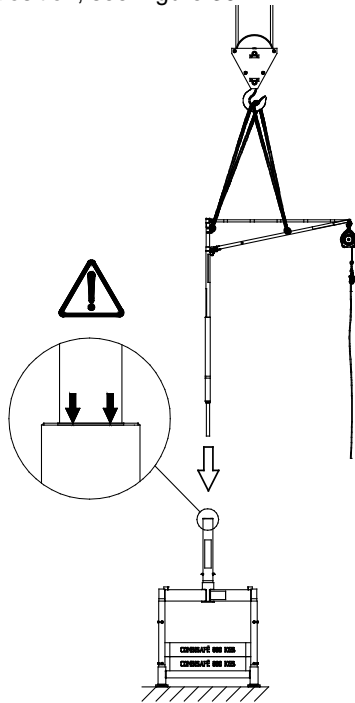

Figure 30. Placement of the SkyReach unit into Top Column 4.7. Beware of the crane and its movement to avoid injuries.

12. Make sure that the steps in the safety check in the *Maintenance* chapter are followed and executed. Now the Loading System MkII is ready to use!

Dismantling

The installation procedure should be performed in reverse order when dismantling.

Transportation

If there is a need to move the Loading System MkII once the unit is assembled and loaded with ballast, it is important that it is handled the correct way to prevent lifting accidents.

1. Use a fork lift truck, place the forks underneath the Base with the forks as wide as possible, see Figure 31. Lift the unit slowly and make sure that no part on the Loading System MkII might be obstructed.

NOTE

A fully loaded Loading System MkII weighs approximately 2000 kg, it is important that a lifting device with a capacity exceeding that value is used.

2. Lift the unit and adjust the feet to their fully inserted position to prevent damage during movement
3. Make sure the unit is lifted high enough to pass any obstacle in the planned route and move it to the new location. Lower the unit to the ground and make sure it is level by adjusting the feet into the desired position. When Loading System MkII is level, remove the fork lift and execute the safety check over again.

NOTE

A complete Loading System MkII unit shall not under any circumstances be lifted with a crane and/or slings! Only with forks placed under the base!

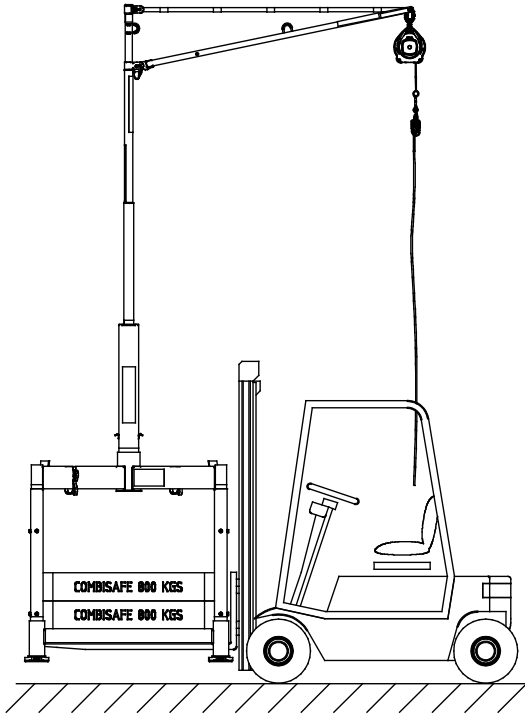

Figure 31. *Lifting the whole unit for transportation.*

Storage

Always store Combisafe products in a dry and ventilated area protected from the effects of the weather and from corrosive substances.

Loading System MkII Base

The Loading System MkII is designed to ease storage when not in use. Since the units can be packed flat, it is easy to store them in a stack. To make sure the Loading System MkII is packed the correct way after usage, please place the parts as in Figure 32 below. Make sure that the Feet are fully screwed in and that the Top Frame is resting on the bottom plates in the Bottom Frame Sleeves.

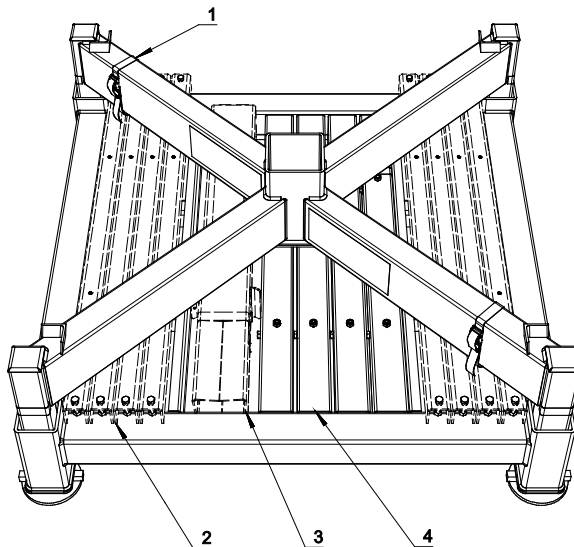

Figure 32. Loading System MkII Base in packed mode.

1. 2 x Combistraps
2. 4 x Formwork Supports on each side (8 Pcs tot.)
3. Top Column 4.7
4. 4 x Corner Post

A total number of 6 flat packed units can be placed together in one stack. On each Top Frame there are four guide plates located to guide the next unit into position.

The flat packed version of the Loading System MkII must be always lifted with a fork lift truck, or equivalent vehicle, and the forks always be placed underneath the horizontal chords of the Bottom Frame, see Figure 33. Remember to only lift one unit at a time.

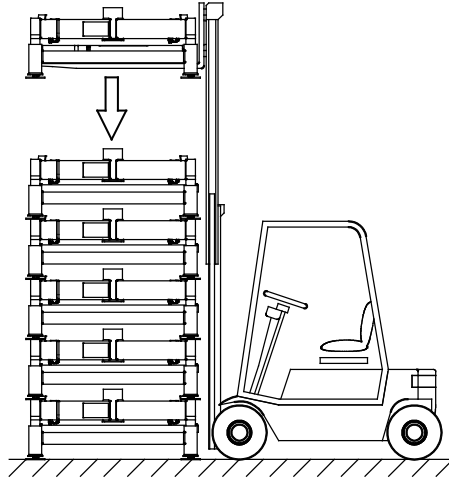

Figure 33. Placement of the 6th packed Loading System MkII with a fork lift truck.

SkyReach Anchor

As already shown in the *Assembly* chapter, the SkyReach Anchor can be folded together to ease packing and transportation.

Recommended operating method

Single Unit usage

For unloading a flatbed with a length of up to 8 m, which will fit into the loading zone as described in Figure 34, a Single Unit is required. The Single Unit consists of one Loading System MkII Base with one SkyReach Anchor, one 6,2 m Falcon Fall Arrest Block, one full body harness, Top Column 4.7 (Art. 8805) or SkyReach Adaptor 5.9 (Art. 8806), please see Figure 3 in the beginning of this document.

This method is based on a width of the flatbed loading area greater or equal to 2,4 m. For any width less than mentioned, please contact Combisafe for advice.

The Base must be positioned centrally to the zone, as shown below.

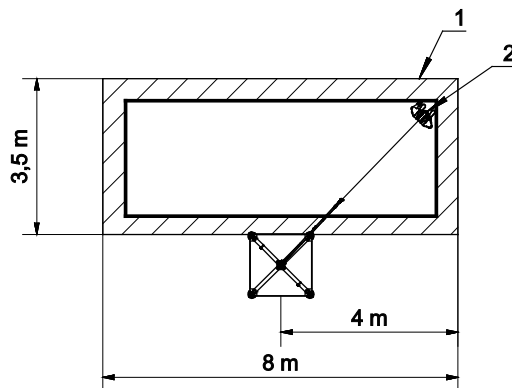

Figure 34. Working area illustration for a Single Unit usage.

1. Loading Zone
2. Operative

Any operative unloading a flatbed trailer should be wearing:

- appropriate footwear,
- reflective vest and helmet with chin strap,
- full body harness,
- harness extender 0.3 m for dorsal anchorage.

Once an operative is wearing the correct harness they can then attach the 0.3 m extender to the harness by looping it through itself, and then attach the other end of the extender to the Retractable Fall Arrest Block, using the karabiner fixing.

NOTE

The operative must be connected to the system before accessing the flatbed.

Double Unit usage

A Double Unit is required, when loading and unloading a flatbed with a length between 8 and 14 m, which will fit into the working zone as described in Figure 35. A Double Unit consists of two Loading System MkII Base units with two SkyReach Anchor units, two 10 m Falcon Fall Arrest Blocks, one full body harness, two Top Column 4.7s (Art. 8809) or two SkyReach Adaptor 5.9s (Art. 8810), please see Figure 3 in the beginning of this document for visual clarification of the parts.

This method is based on a width of the flatbed loading area greater or equal to 2,4 m. By any width less than mentioned, or by flatbed length greater than 14 m, please contact Combisafe for advice.

The operative must be connected to both Loading System MkII units at the same time before accessing the flatbed.

The Bases must be symmetrically positioned with respect to the loading zone according to Figure 35 below.

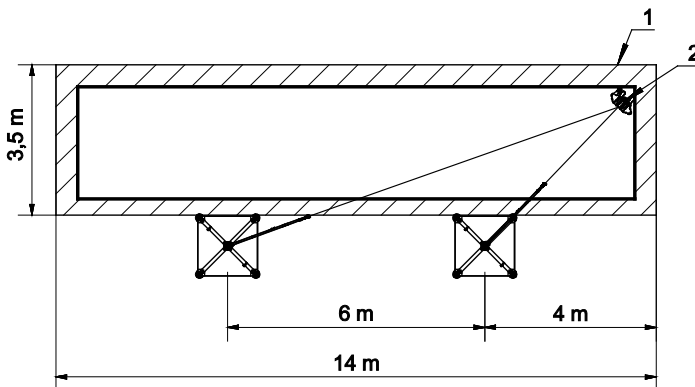

Figure 35. Working area illustration for a Double Unit usage.

1. Loading Zone
2. Operative

Any operative unloading a flatbed trailer should be wearing:

- appropriate footwear,
- reflective vest and helmet with chin strap,
- full body harness,
- harness extender 0.3 m for dorsal anchorage.

Once an operative is wearing the correct harness they can then attach the 0.3 m extender to the harness by looping it through itself, and then attach the other end of the extender to the Retractable Fall Arrest Block, using the karabiner fixing.

NOTE

The Retractable Fall Arrest Block should be a 10 m Falcon Fall Arrest Block to allow the operative to move freely to the farthest extent of the trailer.

The operative must be connected to both systems before accessing the flatbed.

Make sure that the lifelines from each retractable block don't cross, they should at all times run smoothly in their own reel.

Maintenance

Check list prior to usage

Checking of the system shall be performed before each use, if any of the listed statements below are not met, make sure to correct any issue before using the product.

Checking includes the following steps:

Loading System MkII Base unit:

- Ensure that there is no weld damage or deformation to any part of the system.
- Ensure that no corrosion that can affect the strength of the system has occurred.
- Ensure that the Feet are fully adjustable.
- Ensure that the Base unit is level.
- Ensure there are no loose parts e.g. gravel, dirt, concrete etc. in any sleeves or tubes where another part shall be inserted.
- Ensure that the threads on the welding nuts on the Corner Posts are free from dirt that can prevent correct fastening of the bolt. If not using the Formwork Supports, short M12 bolts can be placed in the nuts to protect the threads.
- Ensure that there is no damage to the Precast Kettle concrete block, if such is used.
- Ensure that all items with the insertion marking label on, are readable and are inserted the correct length.
- Ensure the legibility of the product marking.

Top Column 4.7 and SkyReach Adaptor 5.9:

- Ensure that the item is inserted the correct length and that the insertion marking label is readable.
- Ensure that there is no weld damage or deformation to any part of the item.
- Ensure that no corrosion that can affect the strength of the item has occurred.
- Ensure the legibility of the Serial No. marking.

SkyReach Anchor:

- Ensure that no drill holes have been made.
- Ensure that no corrosion that can affect the strength of the product has occurred.
- Ensure there is no weld damage or deformation to any part of the product.
- Ensure that there are no damage to the Lifting Eyes neither to the welds attached to the Eyes.
- Ensure that all bolts are tightened securely.
- Ensure that the Lock Pin is connected to the wire attached to the lower lug on the mast, it is fitted correctly in place, and that it is not damaged or deformed.
- Ensure the legibility of the product marking.
- Ensure that the Hook at the end of the brace is not damaged, and that it can be smoothly placed into the lower lugs on the mast when performing the mounting.
- Ensure that the Fall Arrest Block is completely secured to the Anchor Point.
- Ensure that SkyReach Anchor is fully engaged into the Loading System MkII unit and is free to rotate.

Personal Fall protection Equipment:

- Please follow the manufacturer's recommendations for safety and checking.

Cleaning

Periodically clean the exterior of the parts. Wipe all parts to remove grease or dirt using a damp cloth and if needed use mild detergent, towel dry.

Do not use any detergent that could affect the strength of the parts.

Recycling

When the Loading System MkII has been taken out of service it can be recycled as steel.

Plastic plugs can be recycled according to material specification on the items.

COMBISAFE[®]

SAFETY BY SYSTEMS

COMBISAFE International Ltd
Safety Centre, Cheaney Drive, Grange Park
Northampton UK-NN4 5FB

Tel.: +44 (0)160 4 660600, Fax: +44 (0)160 4 662960
info@combisafe.com, www.combisafe.com